

Operating and maintenance information for proportional valves

directional, flow, pressure controls

safety valves conforming to Machine Directive 2006/42/EC

This operating and maintenance information applies to Atos proportional directional, flow, pressure control valves and safety proportional valves.

It is intended to provide useful guidelines to avoid risks when the valves are installed in the hydraulic system.

It contains important information on the safe and proper installation, commissioning, operation transport and maintenance of the products.

The prescriptions included in this document must be strictly observed to avoid damages and injury.

The respect of this operating and maintenance information grants an increased working life, trouble-free operation and thus reduced repairing costs.

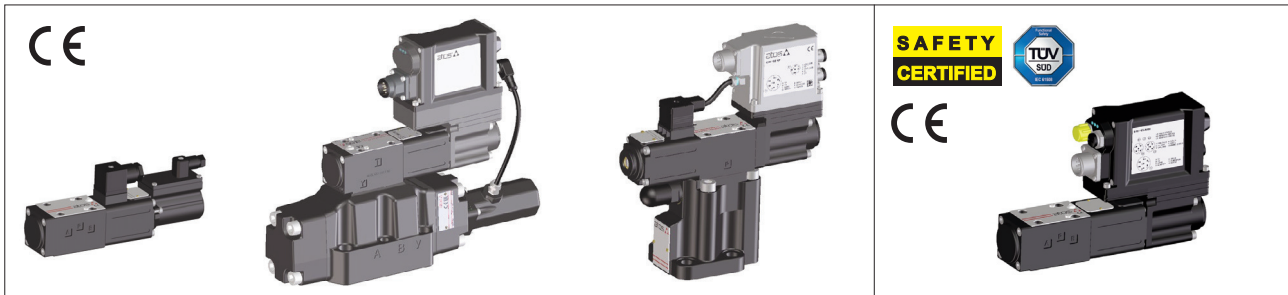

1 SYMBOL CONVENTIONS

Following symbols are used in this documentation to evidence particular risks to be carefully avoided.

In the following are listed the symbol conventions with their meaning, in case of non-compliance with this operating and maintenance information.

	WARNING	Death or serious injury could occur	risk classes to ANSI Z535.6 / ISO 3864
	CAUTION	Minor or moderate injury could occur	
NOTICE	Property damage could occur		
	SAFETY CERTIFIED	Notes relevant to safety proportional valves	
		Information to be observed	

2 GENERAL NOTES

This document is intended for machine manufacturers, assemblers and system end-users.



WARNING

Personal injury and property damage may be caused by incorrect use of the products!

The products have been designed for use in industrial environments and may only be used in the appropriate way.

Before using Atos proportional valves, the following requisites must be met to ensure appropriate use of the products:

- personnel who uses Atos proportional valves must first read and understand the operating and maintenance information, particularly the Safety Notes in section [5](#).
- the products must remain in their original state, no modifications are permitted
- it is not permitted to decompile software products or alter source codes
- damaged or faulty valves must not be installed or put into operation
- make sure that the products have been installed as described in section [6](#) and [7](#)

2.1 Warranty

The expiration of warranty results from the following operations:

- incorrect assembly and commissioning
- improper handling and storage, see 9.4
- improper use, see 5.2
- modification of the original condition

3 CERTIFICATION

Atos range of proportional directional valves, provides functional safety options **/U** and **/K**.

They are designed to accomplish a safety function, intended to reduce the risk in process control systems.

The valves are **TÜV certified** in compliance with **IEC 61508 up to SIL 3** and **ISO 13849 up to category 4, PL e**



4 PRODUCT IDENTIFICATION EXAMPLES - nameplates

4.1 Direct valve with on-board driver/axis card - DLHZO-TES example

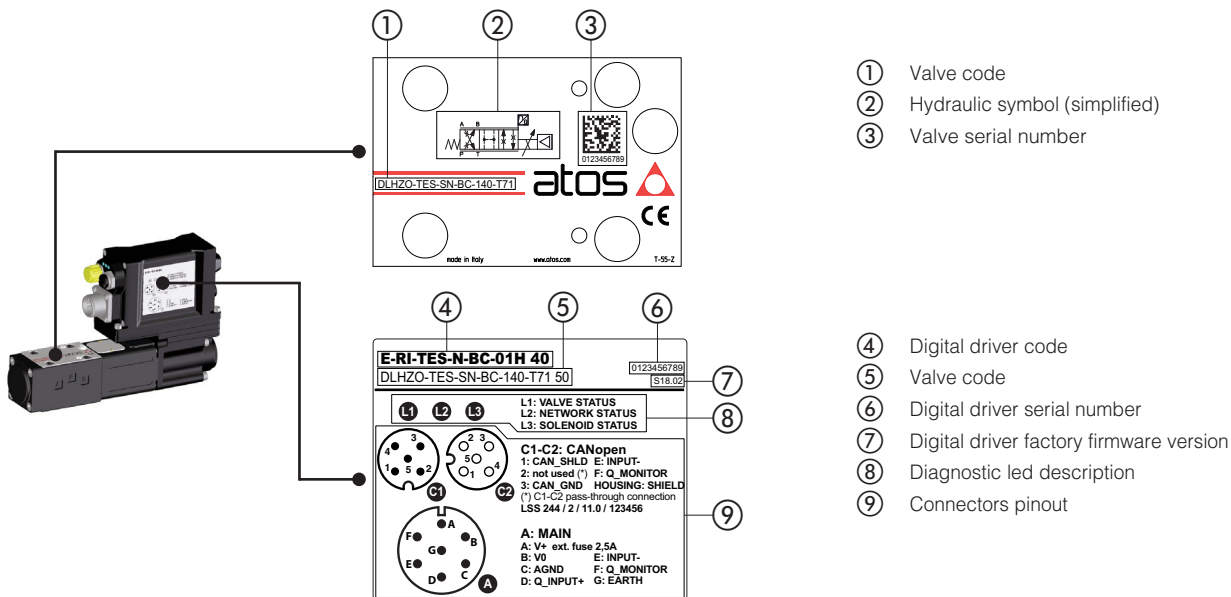

4.2 Piloted valve with on-board driver - AGMZO-AES example

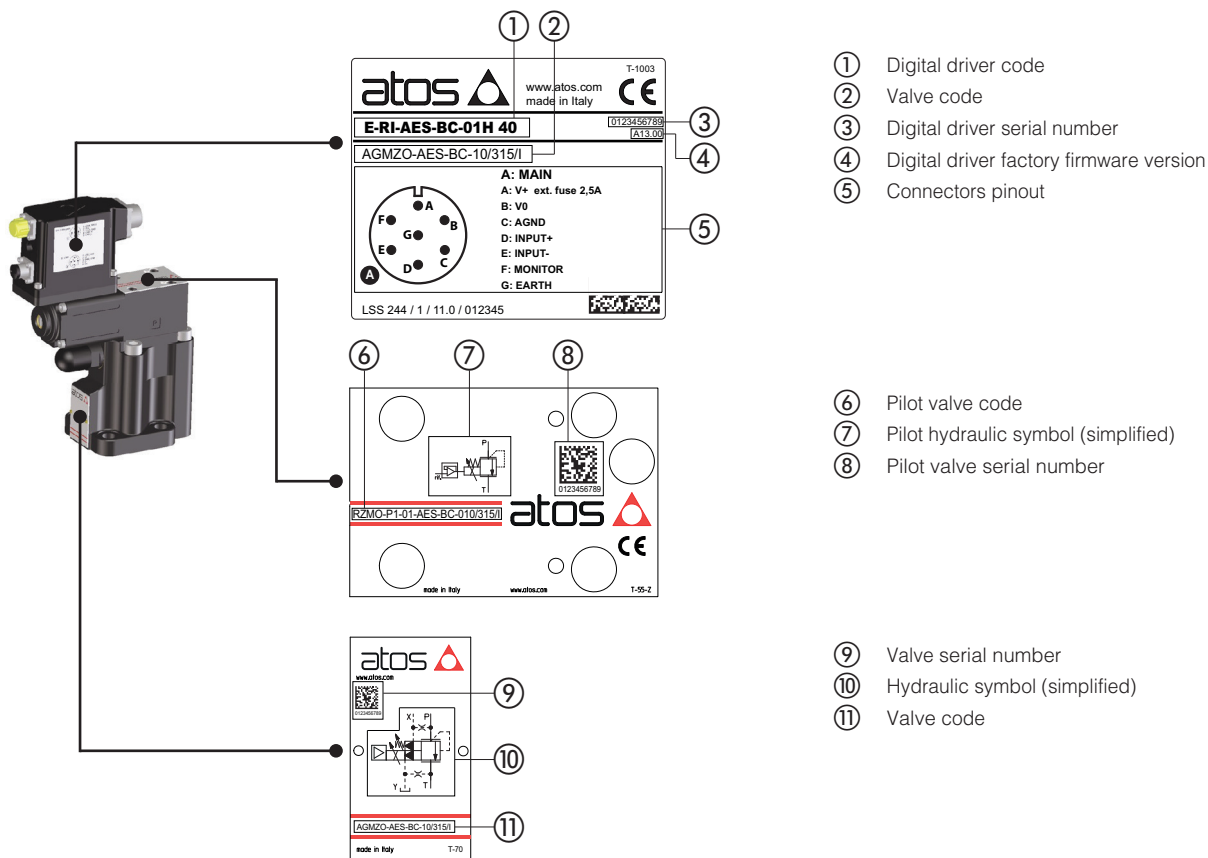

4.3 Piloted valve with on-board driver/axis card - DPZO-LES example

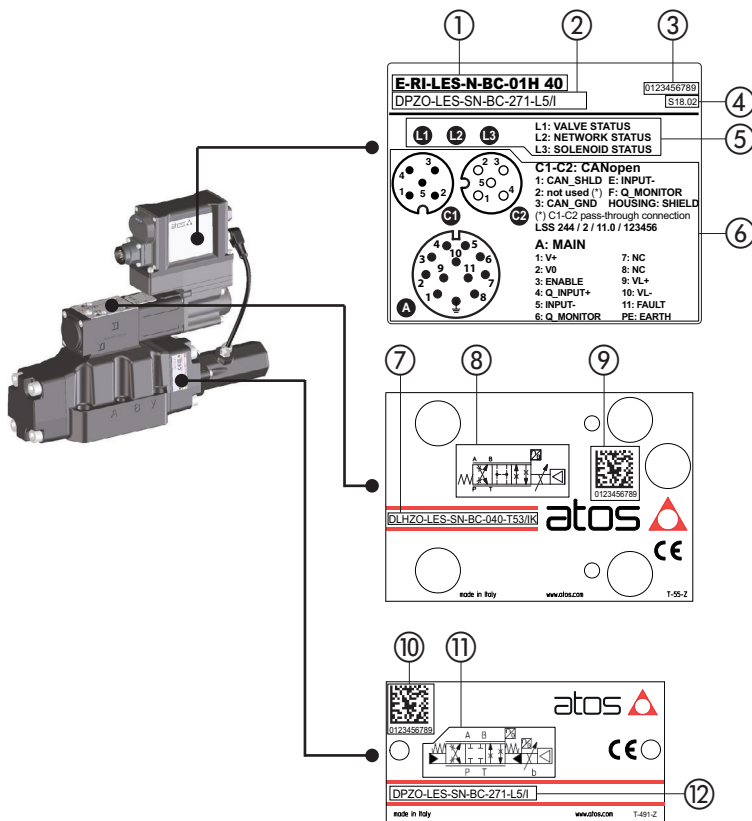

- ① Digital driver code
- ② Valve code
- ③ Digital driver serial number
- ④ Digital driver factory firmware version
- ⑤ Diagnostic led description
- ⑥ Connectors pinout

- ⑦ Pilot valve code
- ⑧ Pilot hydraulic symbol (simplified)
- ⑨ Pilot valve serial number

- ⑩ Valve serial number
- ⑪ Hydraulic symbol (simplified)
- ⑫ Valve code

4.4 Safety piloted valve with on-board driver/axis card - DPZO-LES /K example

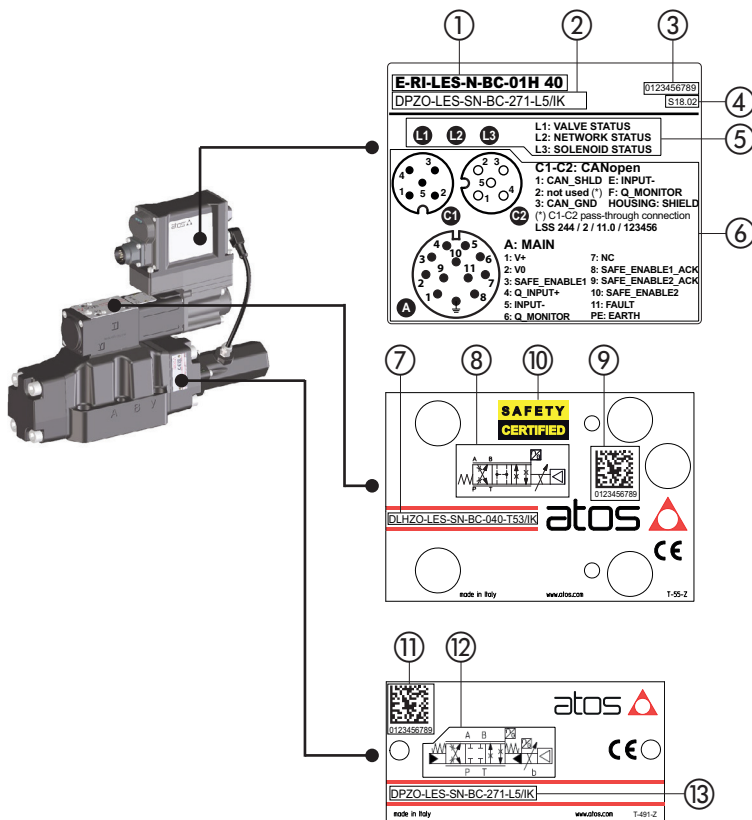

- ① Digital driver code
- ② Valve code
- ③ Digital driver serial number
- ④ Digital driver factory firmware version
- ⑤ Diagnostic led description
- ⑥ Connectors pinout

- ⑦ Pilot valve code
- ⑧ Pilot hydraulic symbol (simplified)
- ⑨ Pilot valve serial number
- ⑩ Logo identifying the safety components

- ⑪ Valve serial number
- ⑫ Hydraulic symbol (simplified)
- ⑬ Valve code

5 SAFETY NOTES

5.1 Intended use

Atos proportional valves are intended for integration in industrial systems and machines or for the assembly with other components to form a machine or a system. They may only be operated under the environmental and operating conditions described in the valves technical tables.



For safety-relevant applications, use only safety proportional valves /U or /K, identified by the Safety Certified logo. The superior control logic in connection with the proportional valve, is responsible for the control of the machine's motion sequence and also for its safety-related monitoring.

5.2 Improper use

Any improper use of the components is not admissible. Improper use of the product includes:

- use in explosive environments
- incorrect storage
- incorrect transport
- lack of cleanliness during storage and installation
- incorrect installation
- use of inappropriate or non-admissible fluids
- operation outside the specified performance limits
- operation outside the approved temperature range

Atos spa does not assume any liability for damage caused by improper use. The user assumes all risks involved with improper use.

5.3 Installation

Installation must be performed following the recommendations contained in the valves technical tables.



WARNING: non-compliance with functional safety



In case of mechanical or electric failures, risk of death or persons injury could occur. Functional safety prescriptions according to EN ISO 13849 must be observed in the hydraulic circuit.



WARNING: fixing bolts

For the valve mounting, use only class 12.9 bolts, with dimensions and length reported in the valves technical tables. Observe the specified tightening torque.

Using inappropriate fixing bolts or insufficient tightening torque, can cause the valve to loosen with consequent leakage of fluid under pressure which may cause personal injury and property damage.



WARNING: hot surface

The valve considerably heats up during operation. Allow the valve to cool down sufficiently before touching it. During operation, touch the valve solenoid only by using protective gloves. Please also observe ISO 13732-1 and EN 982.



WARNING: electronic driver/axis control

Before operating/connect the valve with the Atos CONNECT mobile App or E-SW-SETUP & Z-SW-SETUP PC software, carefully read the user manual: mobile App or PC software can change/inhibit the behaviour of the valve causing damage and injury!

During store/restore operations of the electronic driver/axis control permanent memory:

- current to valve solenoid is switched off: operate store/restore with no active valve regulation in the system
- do not turn off power supply: driver/axis control parameter lose may occur

Faults of driver/axis control may compromise safety or change operating conditions, shut down the driver/axis control immediately and notify qualified personnel.



CAUTION

Use of the valve outside the approved temperature range may lead to functional failures like overheating of the valve solenoid/driver. Only use the valve within the specified ambient and fluid temperature range.



CAUTION: pressurized systems

When working at hydraulic systems with stored energy (accumulator or cylinders working under gravity), proportional valves may even be pressurized after the hydraulic power supply has been switched off.

During assembly and disassembly works, serious injury may be caused by a powerful leaking of hydraulic fluid jet. Ensure that the whole hydraulic system is depressurized and the electrical control is de-energized.



CAUTION: missing equipotential bonding

Electrostatic phenomena, an incorrect earthing or missing equipotential bonding may lead to malfunctions or uncontrolled movements at the machine and thus cause injuries.

Provide for correct earthing or proper equipotential bonding.



CAUTION: penetrating water and humidity

In case of use in humid or wet environments, water or humidity may penetrate at electrical connectors or into the valve electronics. This may lead to malfunctions at the valve and to unexpected movements in the hydraulic system which may result in personal injury and damage to property:

- only use the proportional valve within the intended IP protection class
- ensure that all seals and caps of the plug-in connections are tight and intact

NOTICE

High-pressure water jets could damage the valve seals. Do not use a high-pressure washer for the valve cleaning.

NOTICE: disconnection and connection of plug-in connectors

Do not plug-in or disconnect the electric connector as long as the voltage supply is ON.

NOTICE: impact

Impact or shock may damage the valves. Never use the valves as step.

NOTICE: dirt and foreign particles

Penetrating dirt and foreign particles lead to wear and malfunctions of the valves.

During assembly, be careful to prevent foreign particles such as metal chips getting into the valve or into the hydraulic system.

Do not use linting fabric for the valve cleaning.



Environmental protection

Hydraulic fluids are harmful to the environment.

Leaking hydraulic fluid may leads to environmental pollution.

In case of fluid leakage immediately act to contain the problem.

Dispose of the hydraulic fluid in accordance with the currently applicable national regulations in your country.

Atos components do not contain substances hazardous for the environment.

The materials contained in Atos components are mainly: Copper, Steel, Aluminium, Electronic components, Rubber.

Due to the high content of reusable metals, the main components of Atos can be completely recycled after disassembling of the relevant parts.

6 HYDRAULIC AND MECHANICAL INSTALLATION

6.1 Power packs tank and tubes cleaning

The power unit tank has to be accurately cleaned, removing all the contaminants and any extraneous object. Piping has to be cold bended, burred and pickled. When completely assembled an accurate washing of the piping (flushing) is requested to eliminate the contaminants; during this operation the proportional valves have to be removed and replaced with by-pass connections, or on-off valves.

6.2 Hydraulic connections

Flexible hoses are normally used on pressure line between powerpack and proportional valve and on user lines to connect the actuators. If their potential breakage may cause damages to the machine or system or can cause injure to the operator, a proper retention (as the chain locking at both the pipe-ends) or alternately a protecting carter must be provided.

The proportional valve must be installed as close as possible to the actuator, to assure the maximum stiffness of the circuit and so the best dynamic performances.

6.3 Hydraulic drains and return lines

Drain lines must be connected to the tank without counter pressure. The drain pipe must end above the oil level.

Return line has to be sized in order to avoid variable counter pressure peaks caused by instantaneous flow variations.

6.4 Fluid conditioning

A high-performance system must be thermally conditioned to ensure a limited fluid temperature excursion (generically between 40 and 50°C) so that the fluid viscosity remains constant during operation.

The machine working cycle should start after the prescribed temperature has been reached.

6.5 Air bleeds

Air in the hydraulic circuits affects the hydraulic stiffness and it is the cause of malfunctioning and vibrations.

Air bleeds are provided in the proportional valves.

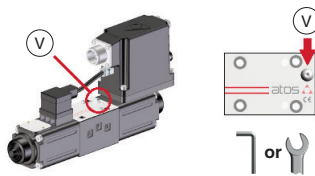

Directional valves air bleeding:

- release 2 or 3 turns the air bleed screw **V**
- cycle the valve at low pressure until the oil leaking from the **V** port is exempted from air bubbles
- lock the air bleed screw **V**

Note: to facilitate bleeding operations, apply a light backpressure (0,5 bar) on T port by adding a check valve on T line

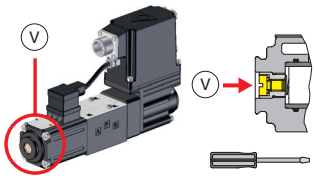

Pressure control valves air bleeding:

- release 2 or 3 turns the air bleed screw **V**
- cycle the valve at low pressure until the oil leaking from the **V** port is exempted from air bubbles
- lock the air bleed screw **V**

Following precautions have to be considered:

- at the system start-up all the bleeds must be released to allow removal of air
- untight the connections of the piping
- the system must be bled at first start-up or after maintenance
- a check valve (e.g. 0,5 bar) should be installed on the return line to tank to avoid emptying of the pipes following a long stop of the system

6.6 System flushing

The whole system must be flushed replacing the proportional valves with specific flushing plates or with on-off directional valves. Make sure that also external pilot lines, if present in the system, are flushed.

In order to obtain the required minimum cleanliness level, the hydraulic system must be flushed for a sufficient time.

A decisive factor for the flushing time is the contamination level of the hydraulic fluid which can only be determined by means of a particle counter.

During the flushing procedure, perform a frequent monitor of the filters clogging indicator, replacing the filter elements when required.

6.7 Hydraulic fluids and operating viscosity range

Mineral oils type HLP having high viscosity index are recommended.

The hydraulic fluids must be compatible with the selected seals.

The type of fluid has to be selected in consideration of the effective working temperature range, so that the fluid viscosity remains at the optimal level.

Hydraulic fluid	Suitable seals type	Classification	Ref. Standard
Mineral oils	NBR, FKM, HNBR	HL, HLP, HLPD, HVLP, HVLPD	DIN 51524
Flame resistant without water	FKM	HFDU, HFDR	ISO 12922
Flame resistant with water	NBR, HNBR	HFC	

Fluid viscosity: 20 ÷ 100 mm²/s - max allowed range 15 ÷ 380 mm²/s



CAUTION: easily inflammable hydraulic fluid

In connection with fire or other hot sources, leaking hydraulic fluid may lead to fire or explosions.

6.8 Filtration

The correct fluid filtration ensures a long service life of the valves and it prevent anomalous wearing or sticking.



CAUTION

Contamination in the hydraulic fluid may cause functional failures e.g. jamming or blocking of the valve spool / poppet. In the worst case, this may result in unexpected actuators movements and thus it constitutes a risk of injury. Ensure adequate hydraulic fluid cleanliness according to the cleanliness class required for the valve.

Max fluid contamination level, see also filter section at www.atos.com or KTF catalog:

- normal operation: ISO4406 class 18/16/13 NAS1638 class 7
- longer life: ISO4406 class 16/14/11 NAS1638 class 5

6.9 Valve fastening

Remove the protection pad located on the valve mounting surface.

Check the correct positioning of the seals on the valve ports.

Verify that the valve mounting surface is clean and free from damages and burrs.

Lock the fastening bolts in cross sequence (like in aside example) at the tightening torque specified in the valve technical table.

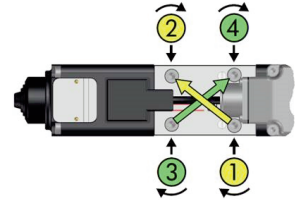

7 ELECTRICAL INSTALLATION

7.1 Power supply

The power supply device must be sized in order to generate the correct voltage when all utilities require the max current at same time; in general 50W max power can be considered for each proportional valve.

Following additional notes have to be considered:

- power supply from a battery: overvoltages (typically greater than 34 Volts) damage the electronic circuits; it is recommended the use of suitable filters and voltage suppressors
- the power supply must be appropriately stabilized or rectified and filtered: apply at least a 10000 μ F/40 V capacitance to single phase rectifiers or a 4700 μ F/40 V capacitance to three phase rectifiers
- a safety fuse is required in series to each power supply: see relevant technical tables for fuses value

7.2 Electrical wiring

The electrical cables must be shielded as indicated in section 8 with shield or cablebraid connected to the ground.

On-board driver/axis card - recommended cables characteristics

Main connector	Cable
7 pin - Metallic / Plastic	LiYCY 7 x 0,75 mm ² max 20 m (logic and power supply) or LiYCY 7 x 1 mm ² max 40 m (logic and power supply)
12 pin - Metallic	LiYCY 12 x 0,75 mm ² max 20 m (logic and power supply)
12 pin - Plastic	LiYCY 10 x 0,14 mm ² max 40 m (logic) plus LiYY 3 x 1 mm ² max 40 m (power supply)

Off-board driver/axis card - recommended cables characteristics

Driver/axis card	Cable
E-BM-AES E-BM-RES E-BM-T*/L* Z-BM-TEZ/LEZ Z-BM-KZ	LiYCY shielded cables: 0,5 mm ² max 50 m for logic 1,5 mm ² max 50 m for power supply
E-MI-AS-IR	2 poles x 0,5 mm ² plus 4 poles x 0,35 mm ² - cable lenght 4 m factory wired external diameter 7,4 mm
E-MI-AC	LiYCY shielded cables: 0,5 mm ² max 40 m for logic 1 mm ² max 40 m for power supply

Note: for transducers wiring cable please consult the transducers datasheet

7.3 Suppression of interferences by electrical noise

When starting the system, it is always advisable to check that feedback, references signal are free from interferences and electrical noise which can affect the characteristics of the signals and generate instability in the whole system.

Electrical noises can be suppressed by shielding and grounding the signal cables, see section 8.

Most of electrical noises are due to external magnetic fields generated by transformers, electric motors, switchboards, etc.

8 SHIELD CONNECTION

The correct shielding of signal cables has to be provided to protect the electronics from electrical noise disturbances, which could affect the valve functioning.

In general following basic rules should be observed:

- power supply cables and signal cables should be routed in separate cable conduits.
- signal cables should be kept far from strong electromagnetic disturbance sources such as electric motor, inverters or transformers.

In the following examples are shown simple shielding criteria to avoid ground loops which may enhance the noise effect and in the worst cases they could cause the driver burning.

Refer to the applicable international standards for details about the shielding criteria.

CORRECT SHIELD CONNECTIONS EXAMPLES

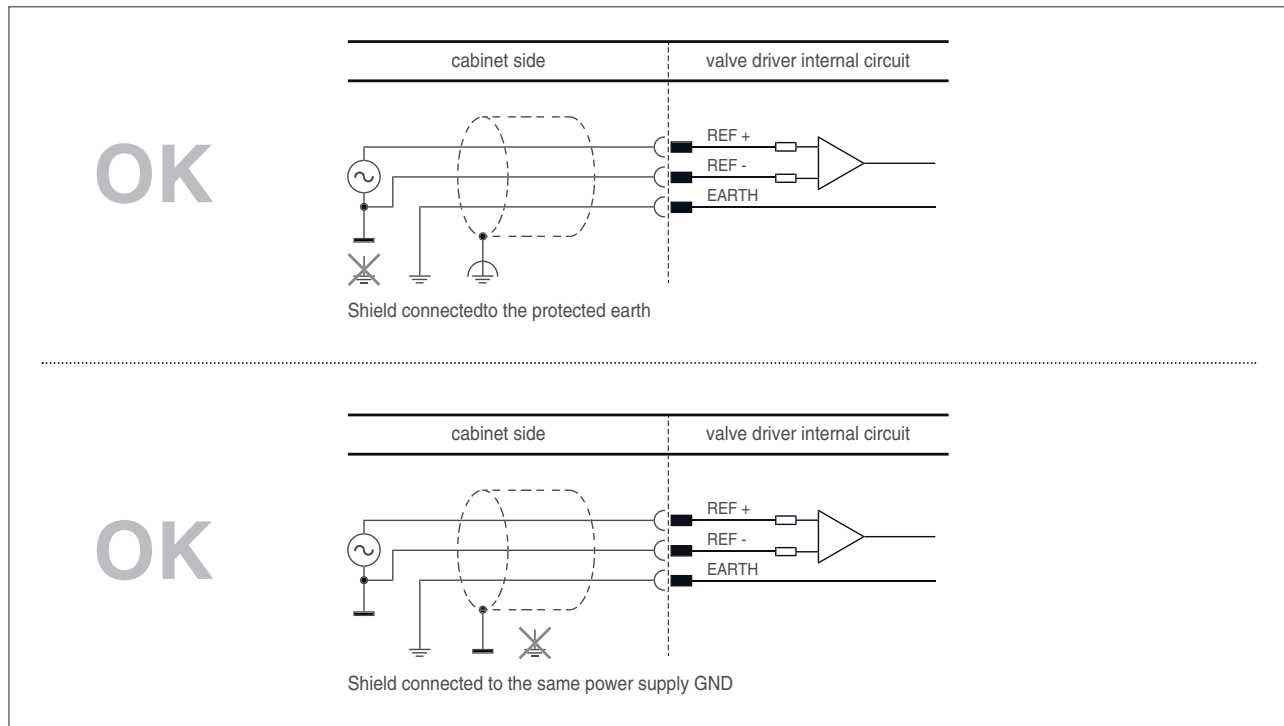

WRONG SHIELD CONNECTIONS EXAMPLES

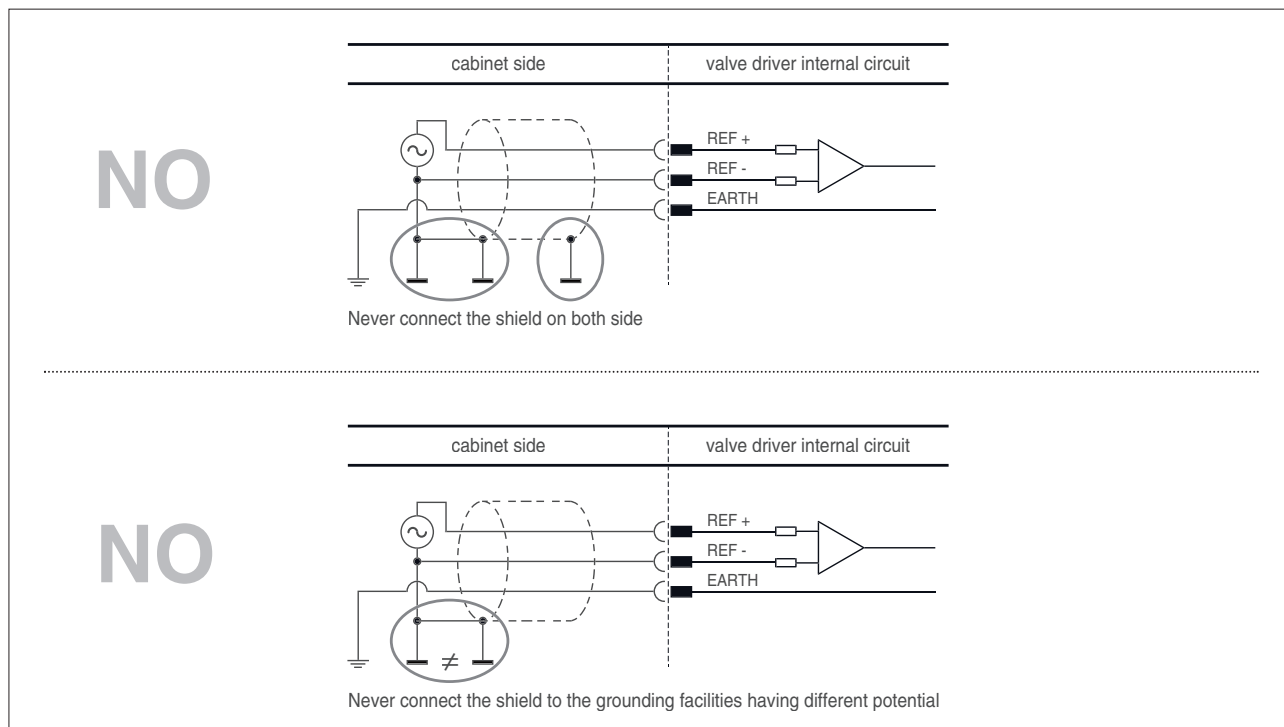

standard earth
 power supply GND
 protected earth

9 MAINTENANCE



Maintenance must be carried out only by qualified personnel with a specific knowledge of hydraulics and electrohydraulics

9.1 Ordinary maintenance

- The valves does not require other maintenance operations except seals replacement
- Results of maintenance and inspection must be planned and documented
- Follow the maintenance instructions of the fluid manufacturer
- Any preventive maintenance should be performed only by experienced personnel authorized by Atos.
- Cleaning the external surfaces using a wet cloth to avoid accumulation of dust layer
- Don't use compressed air for cleaning to avoid any dangerous dust dispersion on the surrounding atmosphere
- Any sudden increment in temperature requires the immediate stop of the system and the inspection of the relevant components

9.2 Repairing

In case of incorrect functioning or beak-down it is recommended to send the valve back to Atos or to Atos authorized service centers which will provide for the reparation.

Unauthorized opening of the valves during the warranty period invalidates the warranty.

9.3 Transport

Atos proportional valves are high-quality products. In order to prevent damage, the valves have to be transported in the original packaging or with equivalent transport protection.

Observe the following guidelines for transportation of valves:

- before any movement check the valve weight reported in the relevant technical table
- use soft lifting belts to move or lift the heavy valves to avoid damages



WARNING

The valve may fall down and cause damage and injuries, if transported improperly.

Use personal protective equipment, such as: gloves, working shoes, safety goggles, working clothes, etc.



WARNING

Do not lift the valve, using the transducer cable

9.4 Storage

Valves are boxed using a VpCi protective packing system, offering best protection to oxidation during components sea transport or long storage in humid environments.

The valve surface is protected with a zinc coating, which guarantees a corrosion resistance of over 200 hours in the salt spray test. Additionally all valves are tested with mineral oil ISO VG 46; the oil film left after testing ensure the internal corrosion protection.

For the valves transporting and storing always observe the environmental conditions specified in the relevant technical tables. Improper storage may damage the product.

The valves can be stored for up to 12 months under the following conditions:

- If there is no specific information in the components technical tables, comply with a storage temperature of $-20\text{ }^{\circ}\text{C}$ to $+50\text{ }^{\circ}\text{C}$
- Do not store the valves outdoors
- Protect the valves against water and humidity in case of storage in open air
- Store the valves in the shelf or on a pallet
- Store the valves in the original packaging or comparable packaging in order to protect them from dust and dirt
- Remove the plastic covers from the valves mounting surface only before the assembly

In case of storage period longer than 12 months please contact our technical office