

Operating and maintenance information for on-off valves

directional, flow, and pressure controls

safety valves with spool position monitor, conforming to Machine Directive 2006/42/EC

This operating and maintenance information applies to Atos on-off directional, flow, pressure control valves and safety valves with spool position monitor. It is intended to provide useful guidelines to avoid risks when the valves are installed in the hydraulic system. It contains important information on the safe and proper installation, commissioning, operation, transport, and maintenance of the products. The prescriptions included in this document must be strictly observed to avoid damages and injury. The respect of this operating and maintenance information grants an increased working life, trouble-free operation and thus reduced repairing costs.



1 SYMBOL CONVENTIONS

Following symbols are used in this documentation to evidence particular risks to be carefully avoided. In the following are listed the symbol conventions with their meaning, in case of non-compliance with this operating and maintenance information.

	WARNING	Death or serious injury could occur	risk classes to ANSI Z535.6 / ISO 3864
	CAUTION	Minor or moderate injury could occur	
NOTICE	Property damage could occur		
	SAFETY CERTIFIED	Notes relevant to safety valves	
		Information to be observed	

2 GENERAL NOTES

This document is relevant to the installation, use and maintenance of on-off directional, flow and pressure control valves. It is intended for machine manufacturers, assemblers and system end-users.



WARNING

Personal injury and property damage may be caused by incorrect use of the products!

The products have been designed for use in industrial environments and may only be used in the appropriate way.

Before using Atos valves, the following requirements must be met to ensure the appropriate use of the products:

- personnel who uses Atos valves must first read and understand the operating and maintenance information, particularly the Safety Notes in section [5](#)
- the products must remain in their original state, no modifications are permitted
- damaged or faulty valves must not be installed or put into operation
- make sure that the products have been installed as described in section [6](#)

2.1 Warranty

The expiration of warranty results from the following operations:

- incorrect assembly and commissioning
- improper handling and storage, see 6.4
- modification of the original condition
- improper use, see 5.2

3 CERTIFICATION

Atos safety valves with spool / poppet position monitor are designed to accomplish a safety function intended to reduce the risk in process control systems.

The valves are **TÜV certified** in compliance with Machine Directive 2006/42/EC Annex IX – EC type-examination certificate for safety components (ref. Annex IV – 21) Norms EN ISO13849-1 and EN ISO13849-2

They can be used in applications up to Category 1, PL c in high demand mode.

The spool / poppet position monitor is factory set in conformity to the relevant norms, and their regulation is properly sealed.



Any tampering of the sealing invalidates the certification

4 PRODUCT IDENTIFICATION EXAMPLES - nameplates

4.1 Directional solenoid valve, direct - DHE example

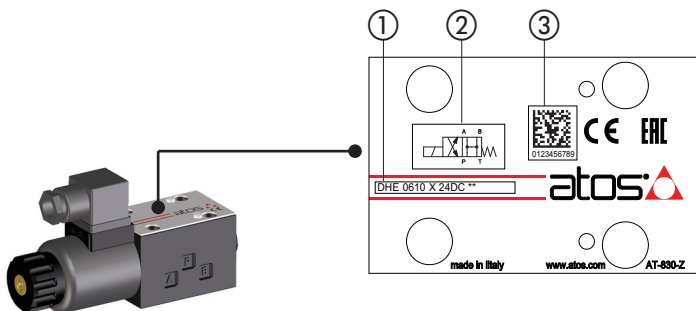

- ① Valve code
- ② Hydraulic symbol (simplified)
- ③ Valve serial number

4.2 Directional solenoid valve, piloted - DPHE example

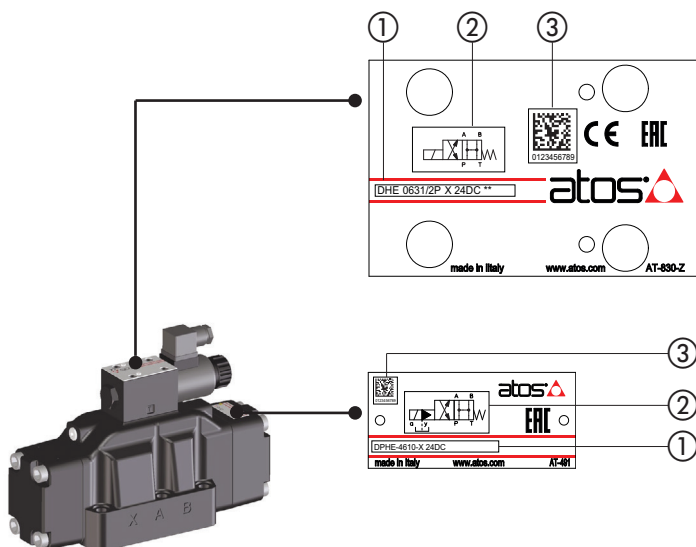

- ① Pilot valve code
- ② Pilot valve hydraulic symbol
- ③ Pilot valve serial number

- ① Valve code
- ② Hydraulic symbol (simplified)
- ③ Valve serial number

4.3 Pressure relief valve, piloted - AGAM example

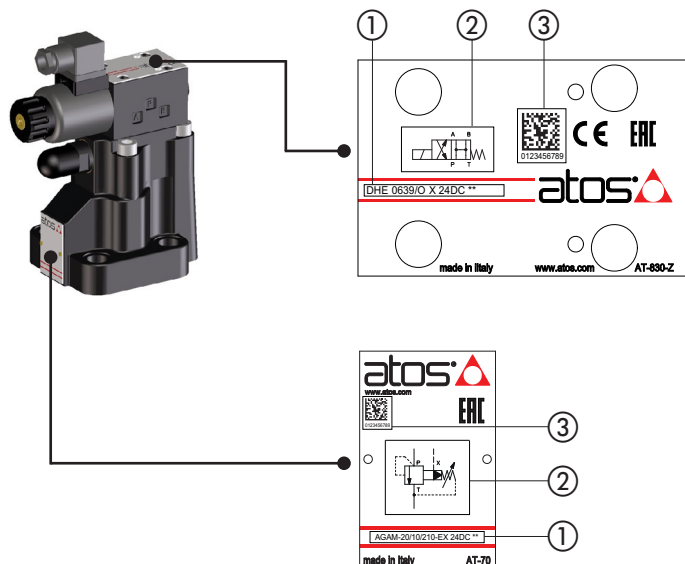

- ① Pilot valve code
- ② Pilot valve hydraulic symbol
- ③ Pilot valve serial number

- ① Valve code
- ② Hydraulic symbol (simplified)
- ③ Valve serial number

4.4 Directional solenoid valve, direct - DHE-*/FV example

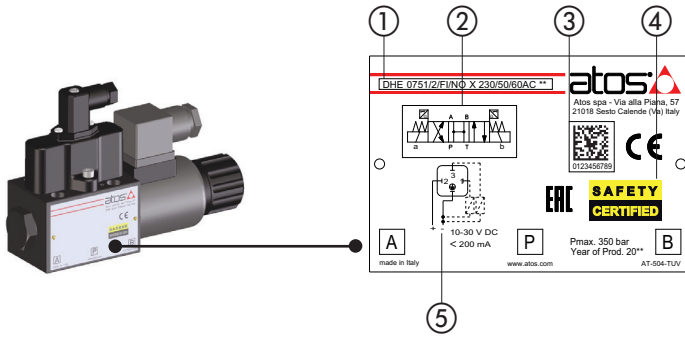

- ① Valve code
- ② Hydraulic symbol (simplified)
- ③ Valve serial number
- ④ Logo identifying the safety component
- ⑤ Sensor electric connection

4.5 Directional solenoid valve, piloted - DPHE-*/FV example

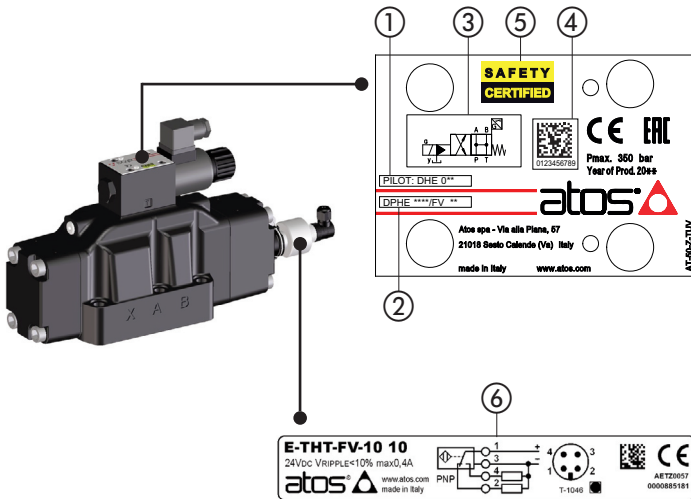

- ① Pilot valve code
- ② Valve code
- ③ Valve hydraulic symbol
- ④ Pilot valve serial number
- ⑤ Logo identifying the safety component
- ⑥ Sensor electric connection

4.6 Pressure relief valve, piloted - LIDA-*/FV example

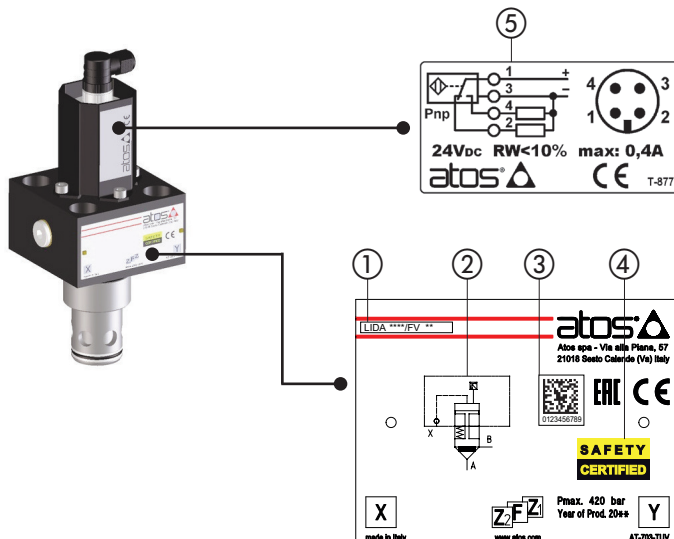

- ① Valve code
- ② Valve hydraulic symbol
- ③ Pilot valve serial number
- ④ Logo identifying the safety component
- ⑤ Sensor electric connection

5 SAFETY NOTES

5.1 Intended use

Atos valves are intended for integration in industrial systems and machines or for the assembly with other components to form a machine or a system. They may only be operated under the environmental and operating conditions described in the valves technical tables.



For safety-relevant applications, use only on-off safety valves identified by the Safety Certified logo. The superior control logic in connection with the safety valve, is responsible for the control of the machine's motion sequence and also for its safety-related monitoring.

5.2 Improper use

Any improper use of the components is not admissible.

Improper use of the product includes:

- use in explosive environments
- incorrect storage
- incorrect transport
- lack of cleanliness during storage and installation
- incorrect installation
- use of inappropriate or non-admissible fluids
- operation outside the specified performance limits
- operation outside the approved temperature range

Atos spa does not assume any liability for damage caused by improper use. The user assumes all risks involved with improper use.

5.3 Installation

Installation must be performed following the recommendations contained in the valves technical tables.



WARNING: non-compliance with functional safety

SAFETY CERTIFIED In case of mechanical or electric failures, risk of death or persons injury could occur. Functional safety prescriptions according to EN ISO 13849 must be observed in the hydraulic circuit.



WARNING: fixing bolts

For the valve mounting, use only class 12.9 bolts, with dimensions and length reported in the valves technical tables. Observe the specified tightening torque.

Using inappropriate fixing bolts or insufficient tightening torque, can cause the valve to loosen with consequent leakage of fluid under pressure which may cause personal injury and property damage.



WARNING: hot surface

The valve considerably heats up during operation. Allow the valve to cool down sufficiently before touching it. During operation, touch the valve solenoid only by using protective gloves. Please also observe ISO 13732-1 and EN 982.



CAUTION

Use of the valve outside the approved temperature range may lead to functional failures like overheating of the valve solenoid. Only use the valve within the specified ambient and fluid temperature range.



CAUTION: pressurized systems

When working at hydraulic systems with stored energy (accumulator or cylinders working under gravity), valves may even be pressurized after the hydraulic power supply has been switched off.

During assembly and disassembly works, serious injury may be caused by a powerful leaking of hydraulic fluid jet. Ensure that the whole hydraulic system is depressurized and the electrical control is de-energized.



CAUTION: missing equipotential bonding

Electrostatic phenomena, an incorrect earthing or missing equipotential bonding may lead to malfunctions or uncontrolled movements at the machine and thus cause injuries. Provide for correct earthing or proper equipotential bonding.



CAUTION: penetrating water and humidity

In case of use in humid or wet environments, water or humidity may penetrate at electrical connectors.

This may lead to malfunctions at the valve and to unexpected movements in the hydraulic system which may result in personal injury and damage to property:

- only use the valve within the intended IP protection class
- ensure that all seals and caps of the plug-in connections are tight and intact

NOTICE

High-pressure water jets could damage the valve seals. Do not use a high-pressure washer for the valve cleaning.

NOTICE: disconnection and connection of plug-in connectors

Do not plug-in or disconnect the electric connector as long as the voltage supply is ON.

NOTICE: impact

Impact or shock may damage the valves. Never use the valves as step.

NOTICE: dirt and foreign particles

Penetrating dirt and foreign particles lead to wear and malfunctions of the valves.

During assembly, be careful to prevent foreign particles such as metal chips getting into the valve or into the hydraulic system

Do not use linting fabric for the valve cleaning.



Environmental protection

Hydraulic fluids are harmful to the environment.

Leaking hydraulic fluid may leads to environmental pollution.

In case of fluid leakage immediately act to contain the problem.

Dispose of the hydraulic fluid in accordance with the currently applicable national regulations in your country.

Atos components do not contain substances hazardous for the environment.

The materials contained in Atos components are mainly: Copper, Steel, Aluminium, Electronic components, Rubber

Due to the high content of reusable metals, the main components of Atos can be completely recycled after disassembling of the relevant parts.

6 HYDRAULIC AND MECHANICAL INSTALLATION

6.1 Power packs tank and tubes cleaning

The power unit tank has to be accurately cleaned, removing all the contaminants and any extraneous object. When completely assembled an accurate washing of the piping (flushing) is requested to eliminate the contaminants.

6.2 Hydraulic connections

Flexible hoses are normally used on pressure line between powerpack and the valve and on user lines to connect the actuators. If their potential breakage may cause damages to the machine or system or can cause injury to the operator, a proper retention (as the chain locking at both the pipe-ends) or alternately a protecting carter must be provided.

6.3 Hydraulic drains and return lines

Drain lines must be connected to the tank without counter pressure. The drain pipe must end above the oil level. Return line has to be sized in order to avoid pressure peaks caused by instantaneous flow variations.

6.4 Fluid conditioning

A high-performance system must be thermally conditioned to ensure a limited fluid temperature excursion (generically between 40 and 50°C) so that the fluid viscosity remains constant during operation. The machine working cycle should start after the prescribed temperature has been reached.

6.5 Air bleeds

Air in the hydraulic circuits affects the hydraulic stiffness and it causes malfunctioning and vibrations. Following precautions have to be considered:

- at the system start-up all the bleeds must be released to allow the air removal
- untight the connections of the piping
- the system must be bled at first start-up or after maintenance
- a check valve (e.g. 0,5 bar) should be installed on the return line to tank to avoid emptying of the pipes following a long stop of the system

6.6 System flushing

The whole system must be flushed for a sufficient time in order to obtain the required minimum cleanliness level. Make sure that also external pilot lines, if present in the system, are flushed.

A decisive factor for the flushing time is the contamination level of the hydraulic fluid which can only be determined by means of a particle counter.

During the flushing procedure, perform a frequent monitor of the filters clogging indicator, replacing the filter elements when required.

6.7 Hydraulic fluids and operating viscosity range

Mineral oils type HLP having high viscosity index are recommended.

The hydraulic fluids must be compatible with the selected seals.

The type of fluid has to be selected in consideration of the effective working temperature range, so that the fluid viscosity remains at the optimal level.

Hydraulic fluid	Suitable seals type	Classification	Ref. Standard
Mineral oils	NBR, FKM, HNBR	HL, HLP, HLPD, HVLP, HVLPD	DIN 51524
Flame resistant without water	FKM	HFDU, HFDR	ISO 12922
Flame resistant with water	NBR, HNBR	HFC	

Fluid viscosity: 15 ÷ 100 mm²/s - max allowed range 2,8 ÷ 500 mm²/s



CAUTION: easily inflammable hydraulic fluid

In connection with fire or other hot sources, leaking hydraulic fluid may lead to fire or explosions.

6.8 Filtration

The correct fluid filtration ensures a long service life of the valves and it prevent anomalous wearing or sticking.



CAUTION

Contamination in the hydraulic fluid may cause functional failures e.g. jamming or blocking of the valve spool / poppet. In the worst case, this may result in unexpected actuators movements and thus it constitutes a risk of injury. Ensure an adequate hydraulic fluid cleanliness according to the cleanliness class required for the the valve.

Max fluid contamination level, see also filter section at www.atos.com or KTF catalog:

ISO4406 class 20/18/15 NAS1638 class 9

6.9 Valve fastening

Remove the protection pad located on the valve mounting surface.

Check the correct positioning of the seals on the valve ports.

Verify that the valve mounting surface is clean and free from damages and burrs.

Lock the fastening bolts in cross sequence (like in aside example) at the tightening torque specified in the valve technical table.

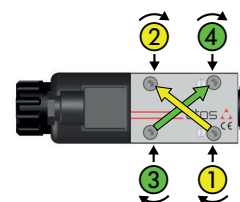

7 MAINTENANCE



Maintenance must be carried out only by qualified personnel with a specific knowledge of hydraulics and electrohydraulics

7.1 Ordinary maintenance

- The valves does not require other maintenance operations except seals replacement
- Results of maintenance and inspection must be planned and documented
- Follow the maintenance instructions of the fluid manufacturer
- Any preventive maintenance should be performed only by experienced personnel authorized by Atos.
- Cleaning the external surfaces using a wet cloth to avoid accumulation of dust layer
- Don't use compressed air for cleaning to avoid any dangerous dust dispersion on the surrounding atmosphere
- Any sudden increment in temperature requires the immediate stop of the system and the inspection of the relevant components

7.2 Repairing

In case of incorrect functioning or beak-down it is recommended to send the valve back to Atos or to Atos authorized service centers which will provide for the reparation.
Unauthorized opening of the valves during the warranty period invalidates the warranty.

7.3 Transport

In order to prevent damage, the valves have to be transported in the original packaging or with equivalent transport protection.

Observe the following guidelines for transportation of valves:

- before any movement check the valve weight reported in the relevant technical table
- use soft lifting belts to move or lift the heavy valves to avoid damages



WARNING

The valve may fall down and cause damage and injuries, if transported improperly.
Use personal protective equipment, such as: gloves, working shoes, safety goggles, working clothes, etc.

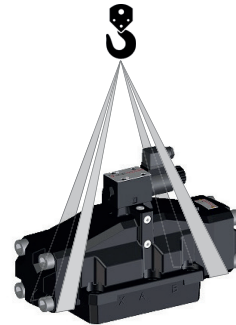

7.4 Storage

Valves are boxed using a VpCi protective packing system, offering best protection to oxidation during components sea transport or long storage in humid environments.

The valve surface is protected with a zinc coating, which guarantees a corrosion resistance of over 200 hours in the salt spray test. Additionally all valves are tested with mineral oil ISO VG 46; the oil film left after testing ensure the internal corrosion protection.

For the valves transporting and storing always observe the environmental conditions specified in the relevant technical tables. Improper storage may damage the product.

The valves can be stored for up to 12 months under the following conditions:

- If there is no specific information in the components technical tables, comply with a storage temperature of $-20\text{ }^{\circ}\text{C}$ to $+50\text{ }^{\circ}\text{C}$
- Do not store the valves outdoors
- Protect the valves against water and humidity in case of storage in open air
- Store the valves in the shelf or on a pallet
- Store the valves in the original packaging or comparable packaging in order to protect them from dust and dirt
- Remove the plastic covers from the valves mounting surface only before the assembly

In case of storage period longer than 12 months please contact our technical office