

PISTON PRESSURE SWITCH type IPNB



Characteristics

TYPE	SETTING RANGE	MAX WORKING PRESSURE	REPEATABILITY	WEIGHT
IPNB-035	6-35 bar	350 bar	$\pm 1\%$ of setting	0.65 Kg.
IPNB-080	10-80 bar			
IPNB-160	12-160 bar			
IPNB-250	15-250 bar	650 bar		
IPNB-350	30-350 bar			
IPNB-630	50-630 bar			

Description

Piston operated, fixed differential, electro-hydraulic pressure switch equipped with electric contact in exchange. When pre-set pressure is achieved, the piston actuates a microswitch. The setting adjustment is achieved by means of a scaled handwheel.

Dimensions

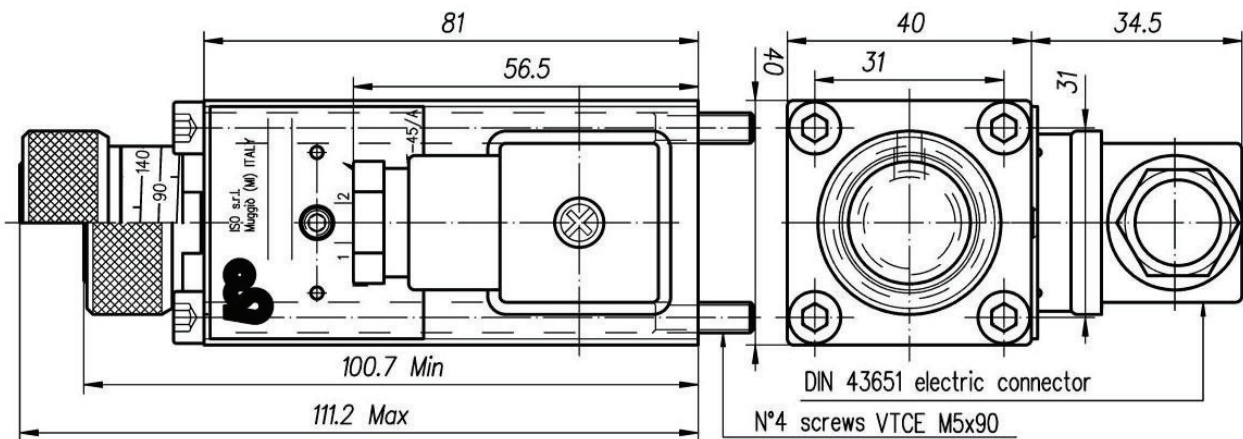

Symbol

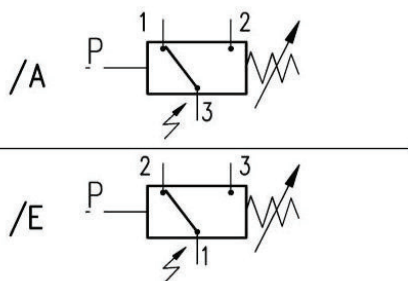

Contacts

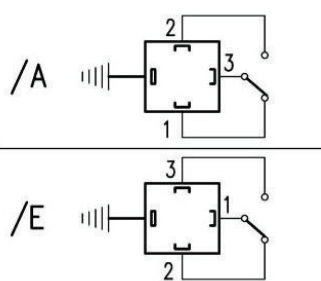

Flange interface

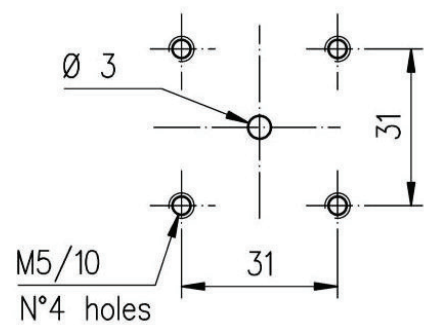

PISTON PRESSURE SWITCH type IPNB



Electric characteristics

	125 AC	250 AC	30 DC	150 DC
Max voltage (Rated load)	7 Amp.	5 Amp.	5 Amp.	0.2 Amp.
Connection frequency	Max. 120 cycles/min			
Protection	IP-65			
Direct current with inductive load	It is suggested to provide an arching contact			

Diagram

DIFFERENTIAL PRESSURE OF IPNB-35 PRESSURE SWITCH

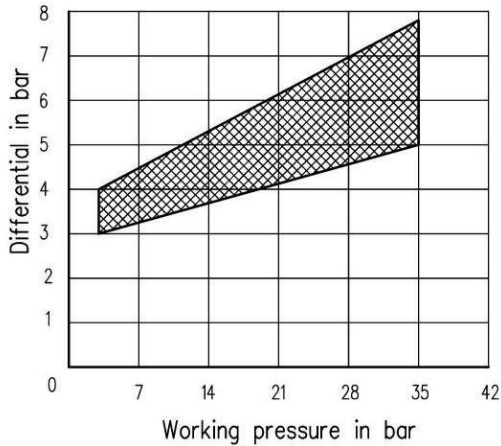

DIFFERENTIAL PRESSURE OF IPNB-80 PRESSURE SWITCH

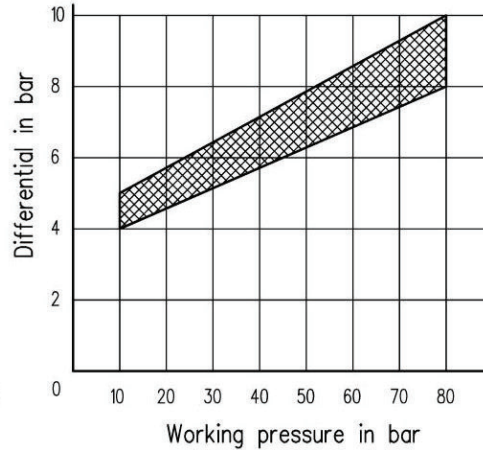

DIFFERENTIAL PRESSURE OF IPNB-160 PRESSURE SWITCH

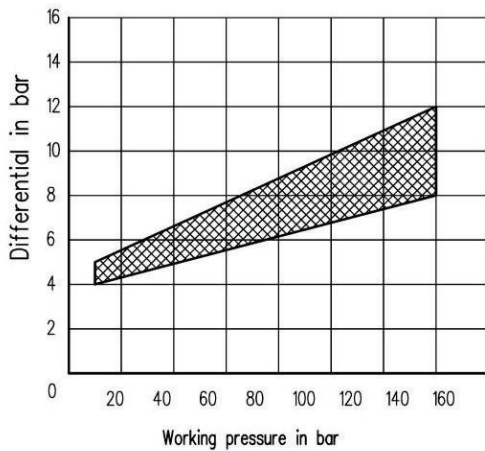

DIFFERENTIAL PRESSURE OF IPNB-250 PRESSURE SWITCH

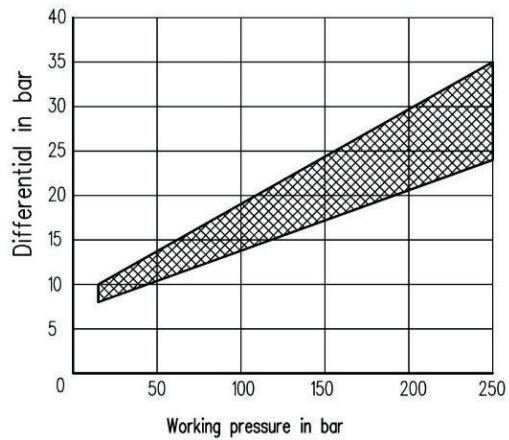

DIFFERENTIAL PRESSURE OF IPNB-350 PRESSURE SWITCH

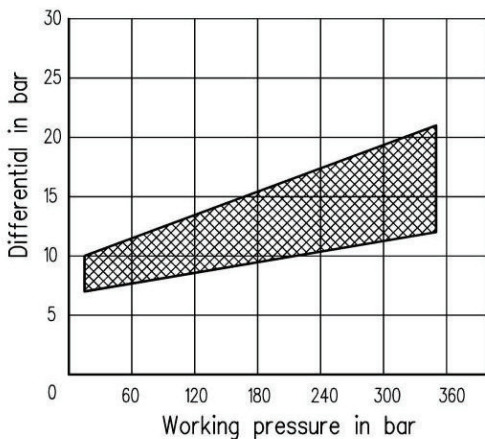

DIFFERENTIAL PRESSURE OF IPNB-630 PRESSURE SWITCH

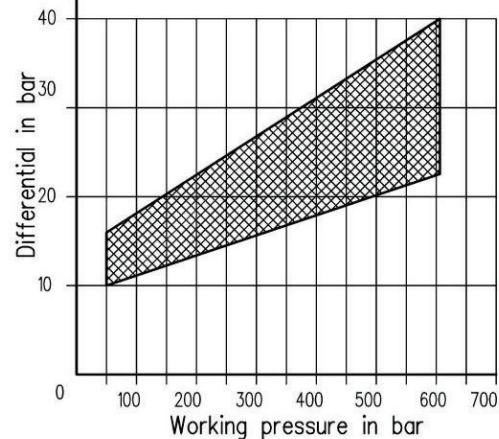

PISTON PRESSURE SWITCH type IPNB



Adaptors

SBM-03/210-IP-**

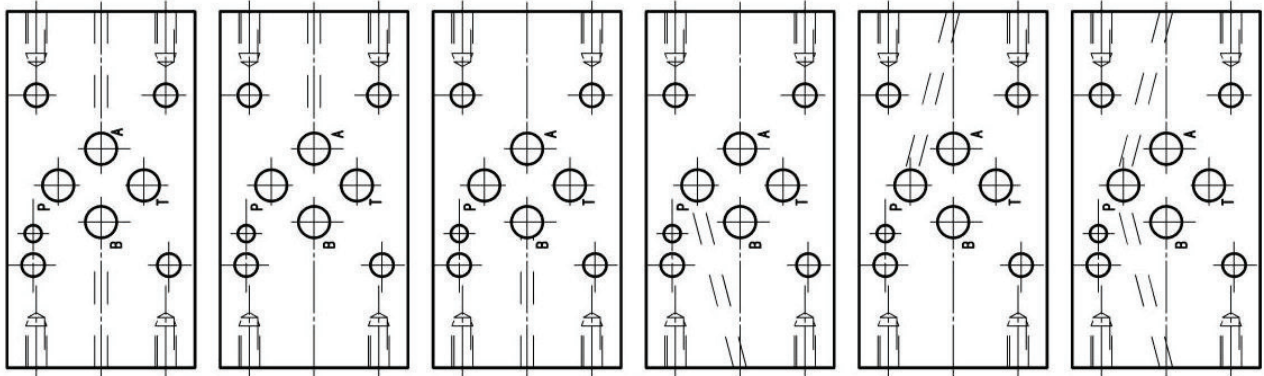

Version AB

Version A

Version B

Version P1

Version P2

Version PP

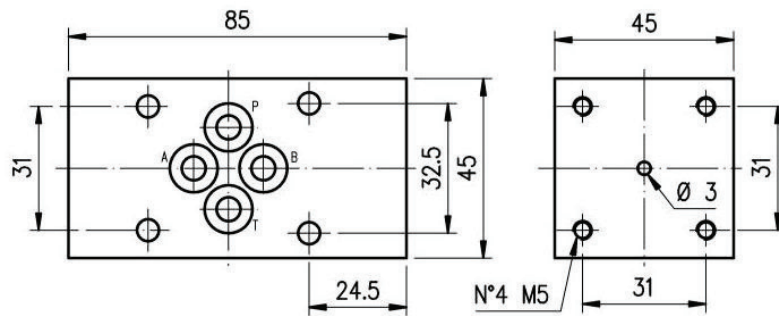

When your order, replace the asterisks with the port/ports on which the device will be mounted.
Es. **SBM-03/210-IP-B** = Pressure switch operating on B port.

SBM-05/210-IP-**

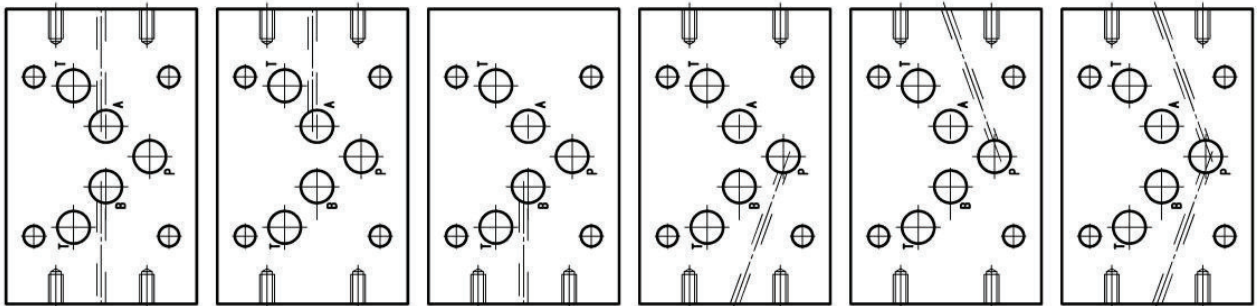

Version AB

Version A

Version B

Version P1

Version P2

Version PP

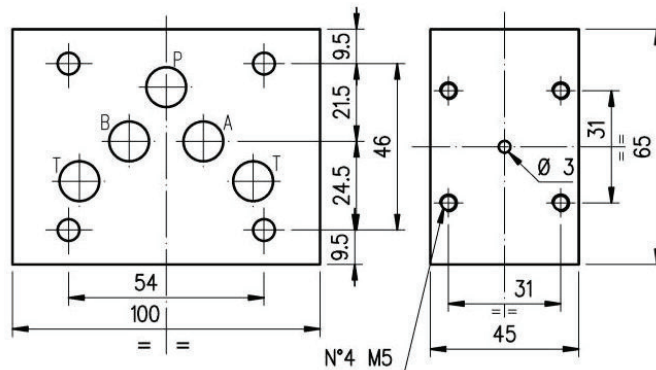

When your order, replace the asterisks with the port/ports on which the device will be mounted.
Es. **SBM-05/210-IP-B** = Pressure switches operating on B port.

PISTON PRESSURE SWITCH type IPNB



BFU-14 (Female adaptor)

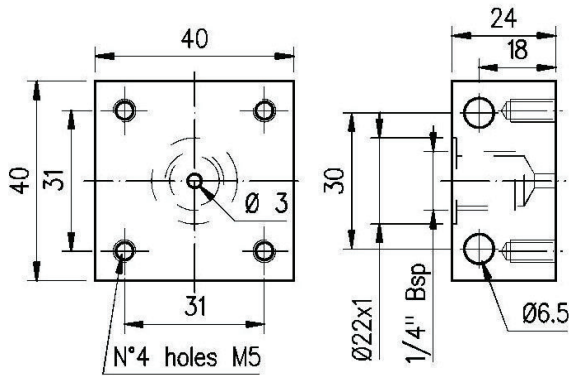

WEIGHT 0.3 Kg.

BMM-**

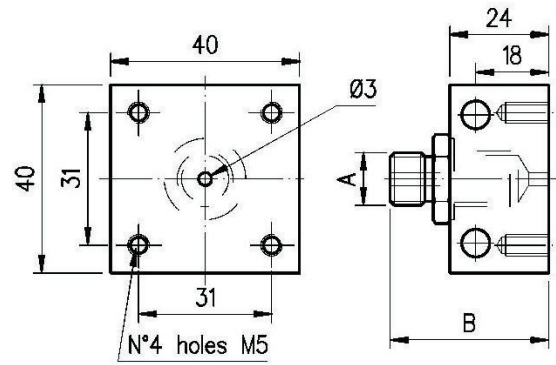

TYPE	A	B
BMM-14	1/4" BSP	41
BMM-38	3/8" BSP	45
BMM-12	1/2" BSP	46

WEIGHT 0.3 Kg.

BFM-**

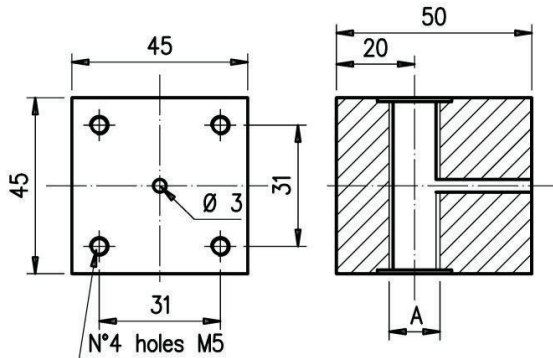

TYPE	A
BFM-14	1/4" BSP
BFM-38	3/8" BSP
BFM-12	1/2" BSP

WEIGHT 0.6 Kg.

BT-1/4x8

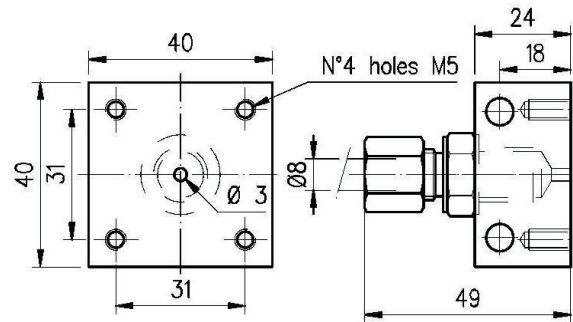

It allows the pressure switch mounting:
 - wall-type by using 2 $\varnothing 6.5$ holes
 - equipped with 1/4" BSP tang for $\varnothing 8$ hose

Installation rules

- The pressure switches type IPNB can be mounted in any position
- Fluid to be used: hydraulic oil in compliance with DIN 51524 rules, viscosity between 30 and 100 mm²/s (cSt) at 40°C
- Recommended filtration of 25 μ
- Hydraulic fluid temperature: from -20° to +75°C

Ordering code

IPNB - *** / *

/A = electric contacts type A /E = electric contacts type E

Pressure setting : 035=6-35 bar 080=10-80 bar 160=12-160 bar 250=15-250 bar 350=30-350 bar 630=50-630 bar

Pressure switch

The product has not to be used as safety device as stated in Article 1, paragraph 2, letter D of Legislative Decree N° 93 dated 25/02/2000.

The component has been designed and manufactured meeting the requirements stated in Directive 97/23/CE (Legislative Decree N° 93/00).

The component is included in the category provided in Article 3, paragraph 3, for which it can be commercialized without CE marking.